

Anti-Islanding Strategy for a PV power plant

ESAM.ZAKI⁽¹⁾

DALAL.HELMI⁽²⁾

FAHMI.BENDARI⁽³⁾

⁽¹⁾ *Computer Dept. Faculty of engineering, Modern Academy of Eng. &Technology, Cairo*

⁽²⁾ *Ministry of Electricity, Renewable Studies Department, Cairo*

⁽³⁾ *Electrical Power Engineering Dept. Faculty of Engineering, Benha University, Cairo*

Abstract:

In this paper: a new strategy of anti-islanding photovoltaic (PV) power plant has been introduced. A new islanding detection scheme based on power electronic signaling technology has been proposed in the literature. By broadcasting a signal on the distribution feeders from the substation to the down-stream *Distributed Generation* (DG), the absence of the signal at the DG site will be a sign of islanding. The scheme is more reliable than regular local detection techniques while it costs much less than transfer trip schemes. The scheme broadcasts a signal from a substation to the DG sites using the distribution feeders as the signal paths. Numerical (microprocessor based) relays, Inverter technology and control have been discussed.

Keywords: Anti-islanding, Distributed Generation, Numerical Relays, Photovoltaic.

1. Introduction

The condition of "Islanding" in Distributed Generators (DG) is an electrical phenomenon that occurs when the energy supplied by the power grid is interrupted due to various factors and DG continues energizing some or the entire load. Thus, the power grid stops controlling this isolated part of the distribution system, which contains both loads and generators [1]. Islanding should be anticipated in DG as the grid cannot control the voltage applied to the loads in islanding conditions and uncontrolled reconnection in an isolated DG can damage the generation equipment or hazard workers on grid users, because a line that is supposedly disconnected from any power source can remain active. Islanding detection techniques are explained briefly in [2].

A photovoltaic model has been produced in [3]. A remote technique for islanding detection is chosen. Our problem here is how to face this phenomenon. Firstly by detecting it and then control it. Our strategy here to make a system depending on numerical relays which have lower cost and less panel space besides PV inverter to control this phenomenon.

Numerical relays and different types of relays have been introduced in [4]. Power line signaling which is a reliable detection technique has been discussed in [5]. Inverter usage and control concept is explained in [6].

2. Power Line Signaling for Islanding Detection

This scheme consists of two devices, a signal generator (SG) and a signal detector (SD). In regular the SG is placed at the substation bus. In case of islanding conditions, opening of switching devices between SG and SD or substation outage, the down-stream DG units will trip. Furthermore, the SG can have auxiliary inputs which give flexibility to the system operators when they need the DGs to be shut down. As the signal carrier is the power line itself, the formation of an island can be detected automatically . Fig.1 illustrates the scheme.

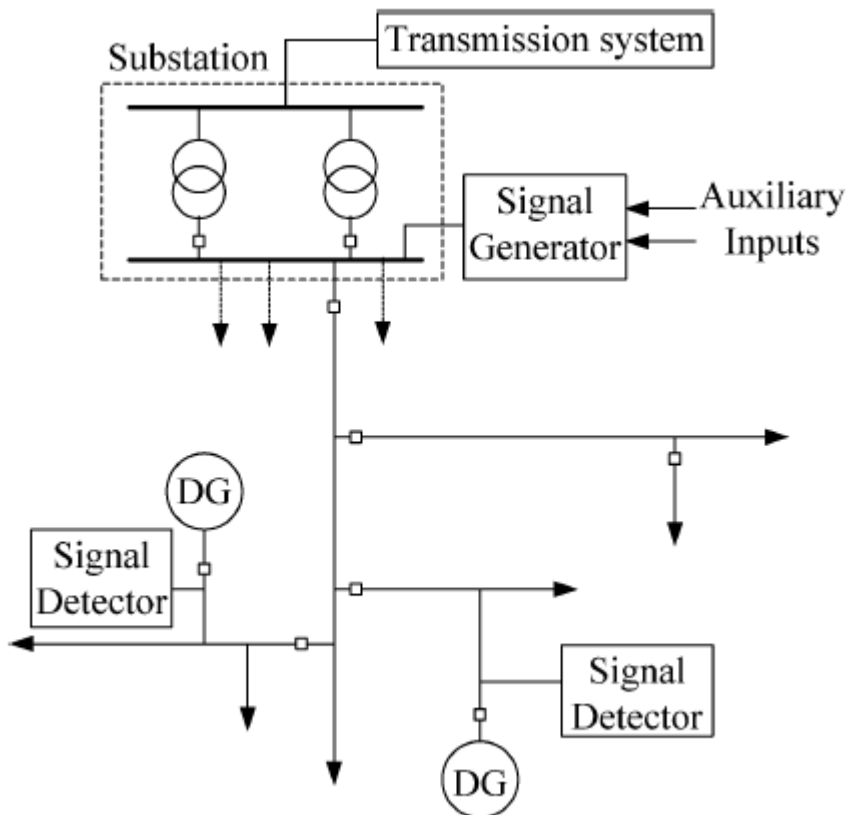

Fig. 1. Illustration for the proposed anti-islanding scheme.

Checking the presence of the broadcast signal at the signal detector position is the key to the islanding protection. The detection process includes signal extraction and a subsequent signal processing method. A phase to ground channel (B-G) is selected as the detection channel. In order to extract the signal from this voltage waveform, subtraction of two consecutive cycles is used. Mathematically we can describe this subtraction by:

$$v_{signal}(t) = V_B(t) - V_B(t - T) \quad (1)$$

Where T is the period of fundamental frequency, 60 Hz, waveform. For the dc component, the first harmonic and the other integer harmonics (for which, T will be an integer multiple of their own period) the previous equation will become:

$$a_h \sin(h\omega(t)) - a_h \sin(h\omega(t-T)) = 0 \quad (2)$$

Figure(2) shows Subtraction pattern for signal extraction. According to this figure, subtraction results in two cycles for every four cycles of the detection channel voltage. For details we can change t-domain to f-domain and have a model comparing between cycles as mentioned in[5]. For disturbances in this model which affects the signal performance, we can deal that by system grounding and system disturbance analysis.

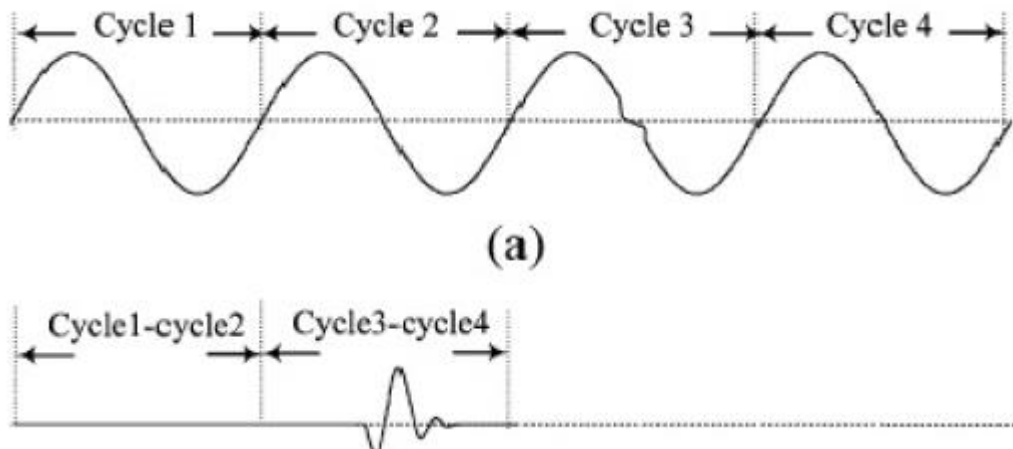

Fig. 2 Subtraction Pattern for signal Extraction

3. Numerical Relays

Numerical relays has benefited many years of successful implementation of electromechanical and static relays. We can replace existing electromechanical distance relays by numerical ones partially and economically. A total of fourteen electromechanical relays will be removed of which six distance relays (3 for phase and 3 for ground) and the remaining devices are timers and auxiliary relays [4].

4. Inverter Specifications

An inverter used in grid connected PV systems must satisfy some specifications, which are given by national and international standards. The specifications for the PV module to the inverter, and the inverter enhanced with grid are presented.

4.1 Ambient Temperature

The PV cell temperature can reach 78 °C on sunny day (irradiance: 1200 W/m² and ambient temperature: 40 °C). Thus, if the inverter is to be mounted on the rear side of the PV module, it has to withstand a temperature of almost 80 °C.

4.2 Life Time and Reliability

The inverter should be maintenance-free during the AC-Module's lifetime. This is desirable while the AC-Module is intended to be a 'plug and play' device, which can be operated by persons without specialized training. The inverter lifetime is then directly specified according to the lifetime of the included PV module.

4.3 Personal safety

Some countries require a transformer between the inverter and the grid if a DC monitoring device is not included. Other countries demands HPFI-relay (High-Sensitive, Pulsing direct current, earth Fault circuit breaker), if the transformer is omitted. System ground is required in some countries if the open circuit PV module exceeds 50 V.

System ground is not required for the developed inverter, since the inverter is designed to maximum 50V open circuit voltage, c.f. section 3.2.3. Thus, galvanic isolation is not required between the PV module and the grid, when personal safety is the issue.

4.4 PV Module Interface

Nominal power, starting power, maximum open-circuit voltage, maximum power point tracking, maximum short circuit current, input ripple and over voltage protection must be taken into consideration when setting up the specifications of PV module interface. Also inverter grid interface issues such as voltage, maximum power, standby losses, DC current, frequency, current harmonics, inrush current and grounding have been considered [6].

5 Description of Inverter Performance

A primary objective of this work is to develop an inverter performance model applicable to all commercial inverters used in photovoltaic power systems, providing a versatile numerical algorithm that accurately relates the inverter's ac-power output to the dc-power input. The model developed requires a set of measured performance parameters (coefficients). The complexity and the accuracy of the performance model are "progressive" in the sense that the accuracy of the model can be improved in steps, as more detailed test data are available. Manufacturers' specification sheets provide initial performance parameters, field measurements during system operation provide additional parameters and accuracy, and detailed performance measurements as conducted by recognized testing laboratories [7] provide further refinement of parameters used in the model.

6. Inverter Choice Selection

For a PV power plant design, the choice of the inverter depends on more factors and national standards. Currently the main standards which govern inverters in the IEEE 1547 "Standard for Interconnecting Distributed Resources with Electric Power Systems" and UL 1741 "Standard for Safety for Inverters, Converters, Controllers and Interconnection System Equipment for Use with Distributed Energy Resources." IEEE 1547 establishes criteria and requirements for interconnection of DER with electric power systems [3].

A good inverter must have a system for detecting ground fault errors in the PV array and has an active safety algorithm to protect against islanding phenomenon. Such inverter detects the grid voltage that it must feed in automatically depending on the voltage and the phase angle between L1-N and L2-N, the inverter determines whether a wrong grid voltage is detected giving an error message.

6. Islanding Modelling

Depending on matlab/Simulink model and pss/e program, and referring to model in [5], figures (3,4,5,6) show the behavior of voltage, frequency, active power and reactive power during tripping and a PV power plant became islanded.

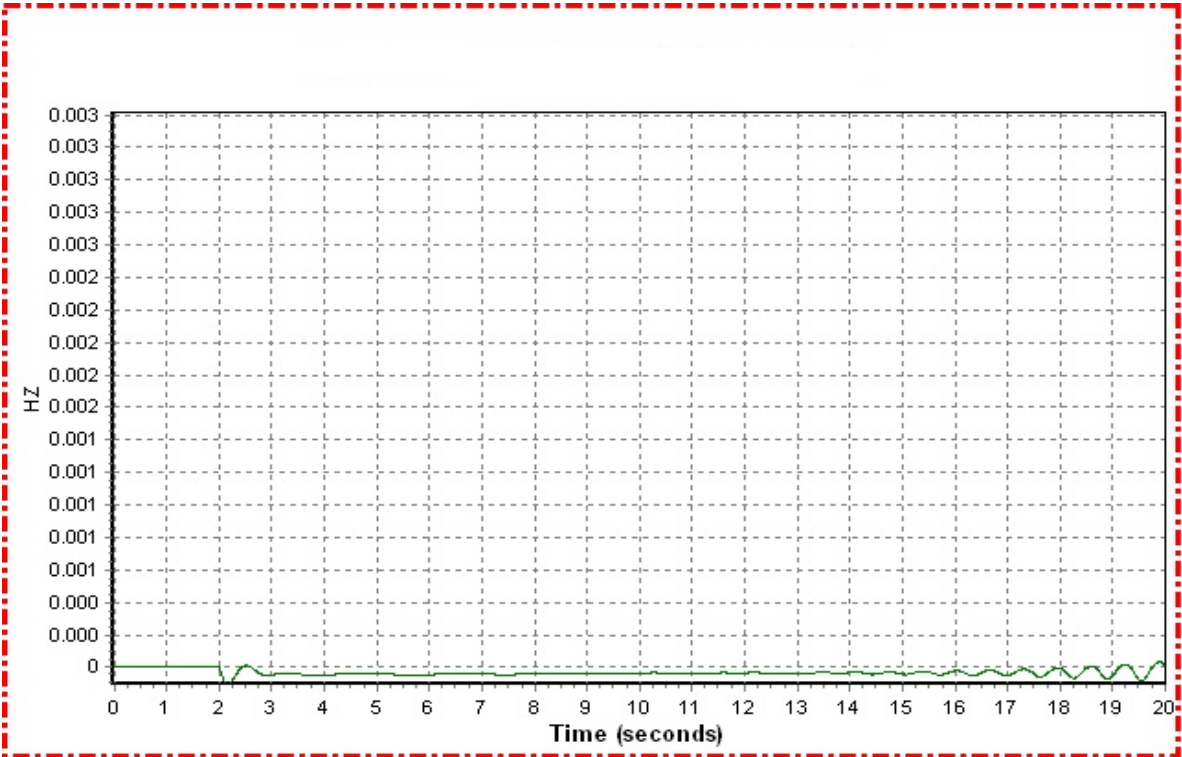

Fig. 3 frequency during tripping

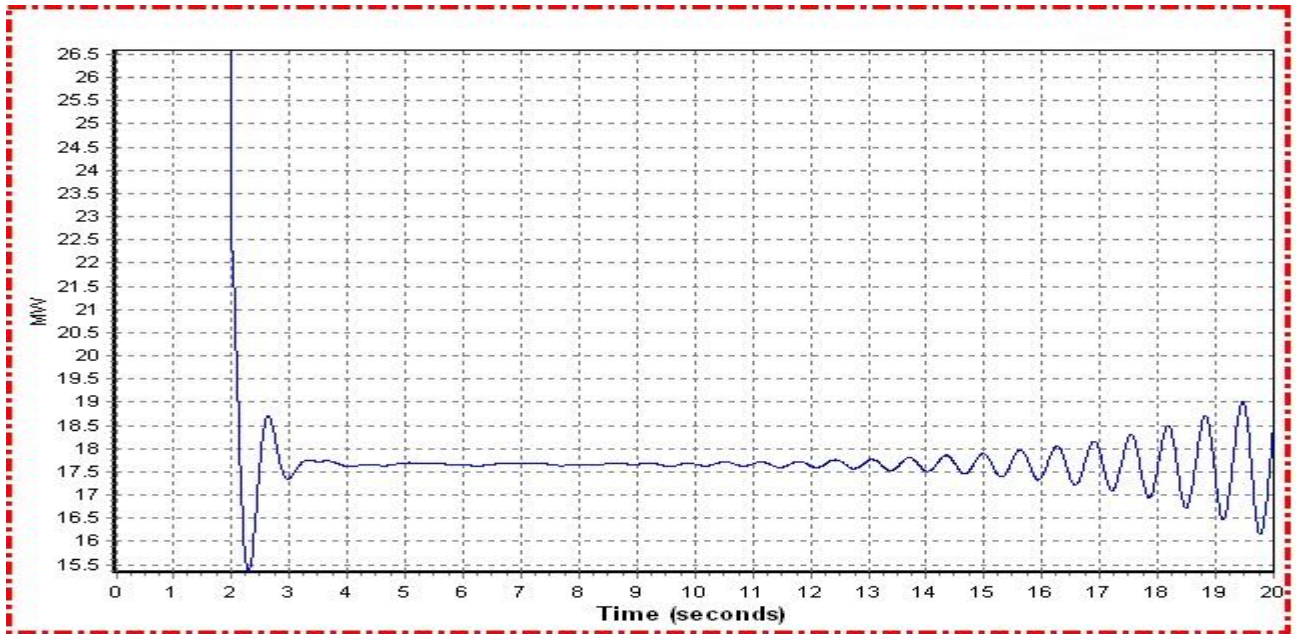

Fig.4 active power during tripping

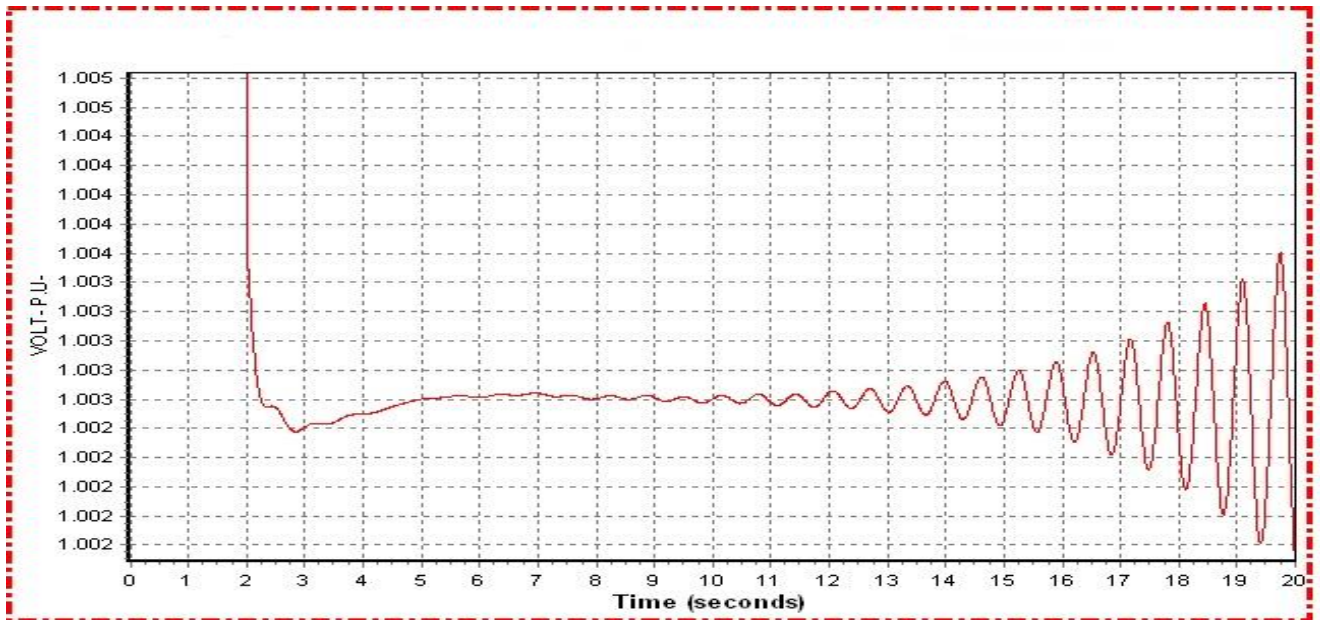

Fig. 5 voltage during tripping

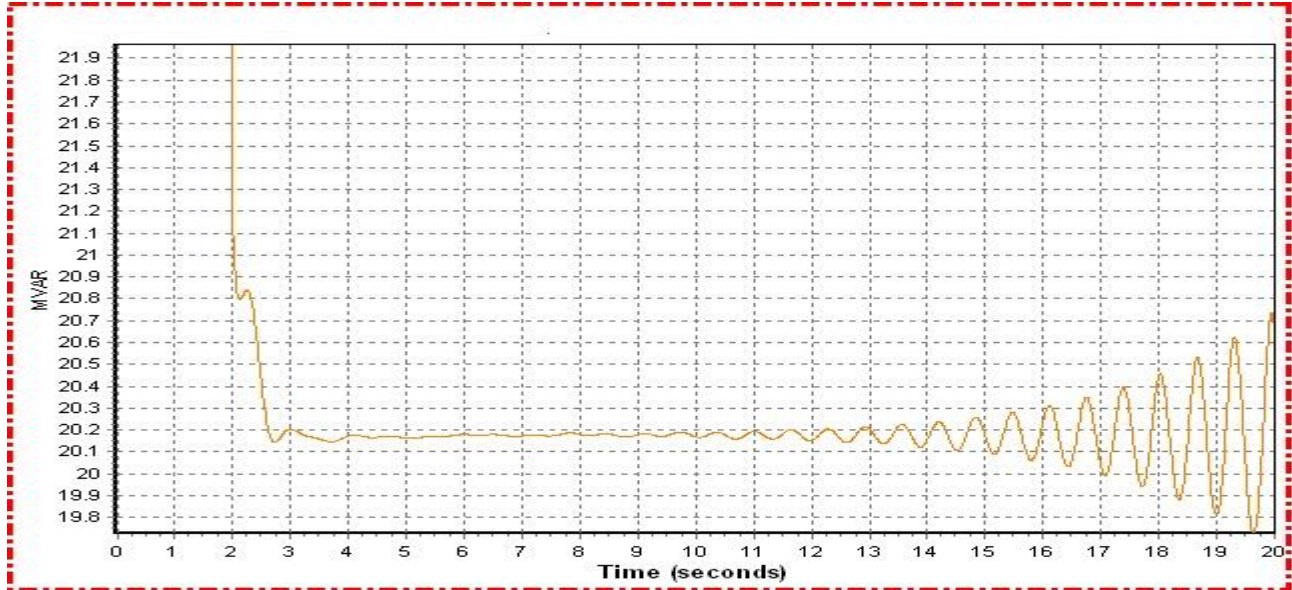

Fig. 6 reactive power during tripping

From the previous figures, it is clear that there are some oscillations and due to inverter, the system was able to be stable again.

6. Conclusion

To control islanding phenomenon and making the system protection adaptive and more stable, the strategy depends on three effective elements depending on embedded systems in their construction, which making them adaptive and gives the system stability enough to face islanding phenomenon. These elements are:

1. Remote islanding detection technique depending on power line signaling.
2. Adaptive relays, especially numerical relays which have their own settings, characteristics and logic functions. These functions changed on line a timely manner by means of externally signals or control action.

3. PV inverters : which have a main effect for stabilizing the isolated PV power plant which is out of control of utility grid.

Using a software package and by addressing each element in power system utility, we can monitor and control the system easy.

7. Recommendations

In order to achieve a high performance PV power plant, automatic data acquisition and monitoring technology is essential. This allows the plant to be monitored and faults can then be detected and rectified before they have an appreciable effect on production.

Some recommendations must be taken into consideration to get a good strategy facing islanding phenomenon as follow:

- Backup system for inverters to control the system long time as possible.
- Coding and addressing of all system elements, and by a package of software, controlling the system could be easy.
- Using two inverters, especially in radial systems meeting the non detection zones in case of islanding occurrence.
- Replacing electromechanical relays by numerical relays makes control easier.

5. References

- [1] Cesar Trujillo, David Velasco, Emilio Figueres and Gabriel Ggarcera “Local and Remote Techniques for Islanding Detection in Distributed Generators”, Distributed generation book, D.N.GAONKAR, In-Teh, Olajnica 19/2, 32000 Vukovar, Croatia, 2010.
- [2] Hèctor Beltran, Francisco Gimeno, Salvador Seguí-Chilet and Jose M. Torrelo, "Review of the Islanding Phenomenon Problem for Connection of Renewable Energy Systems", Instituto de Tecnología Eléctrica Av. Juan de la Cierva, 24 - Parc Tecnològic 46980 Paterna, València (Spain).
- [3] Anca D.Hansen, Poul Sorensen, Lars H.Hansen and Henrik Binder, "Models of Stand-Alone PV System", Riso National Laboratory, Roskilde, December,2000.
- [4] Mohamed A. Ibrahim "Power System Protection &Control", 2012. ISBN 978-0-470-91681-0(CLOTH).
- [5] Essam Z.Mohammed, "A Power Line Signaling Based Technique for Anti- Islanding detection", Al-Azhar University, 2014.
- [6] Kjær, Søren Bækhøj, "Design and Control of an Inverter for Photovoltaic Applications", Aalborg Universitet, 2005.
- [7] David L. King, Sigifredo Gonzalez, Gary M. Galbraith, and William E. Boyson, "Performance Model for Grid-Connected Photovoltaic Inverters", Sandia National Laboratories, September 2007.